

Kumo

by Yum Asia



Fuzzy Logic Multifunction
YumCarb Rice Cooker

YUMCARB

5.5 cup - 1.0 litre (1-5 people)

Models - YUM EY10D-SEA, YUM EY10L-SEA

Ceramic Bowl
Ninja



INDEX

1.	IMPORTANT SAFEGUARDS Please follow these instructions.....	3
2.	APPLIANCE DESCRIPTION.....	6
2.1	APPLIANCE DESIGN.....	6
2.2	CONTROL PANEL DISPLAY.....	7
3.	APPLIANCE OPERATION.....	7
3.1	BEFORE USE.....	7
3.2	NAVIGATING THE CONTROLS.....	7
3.3	HOW TO USE THE RICE COOKER FUNCTIONS.....	7
3.4	HOW TO USE THE KEEP WARM FUNCTION.....	9
3.5	HOW TO USE THE OTHER COOKING FUNCTIONS.....	9
3.6	CANCELLING PROGRAMMES.....	10
3.7	HOW TO USE THE DELAYED START (PRESET) FUNCTION.....	10
4.	COOKING GREAT TASTING RICE.....	11
4.1	HOW TO COOK PERFECT RICE.....	11
4.2	OUR TIPS FOR RICE COOKING AND GETTING PERFECT RESULTS.....	11
5.	HOW TO USE THE STEAM FUNCTION.....	12
6.	RECIPES.....	13
7.	COOKING WITH OTHER GRAINS/PULSES IN KUMO.....	14
8.	YUMCARB EXPLAINED.....	15
9.	CLEANING AND MAINTENANCE.....	16
10.	REPLACEMENT PARTS.....	17
11.	TROUBLESHOOTING GUIDE.....	17
12.	SPECIFICATIONS AND COOKING TIMES.....	19
13.	CERTIFICATION AND WARRANTY.....	19

Model YUM-EY10

Kumo

Thank you for choosing this Yum Asia Multi-Function YUMCARB Rice Cooker Model YUM-EY10 which we named 'Kumo'.

Here at Yum Asia our experience of working with major leading brands of rice cookers and technology has given us the knowledge required to produce this perfect cooker. This means that this product has been designed to the highest standards of quality, functionality and design and more importantly with the passion we have for cooking great rice!

We guarantee that you will be satisfied with your new appliance and this is backed up by our comprehensive warranty service. For further details, go to www.yum-asia.com/sea/warranty or see the warranty card enclosed. Keep these operating instructions stored away with your warranty card, receipt, and, if possible, the cardboard box and packaging. The latest version of these instructions may be found for viewing or download at www.yum-asia.com

If you have any questions about this product, cooking advice or anything else then please contact us at hello@yum-asia.com and we will be happy to help.

ATTENTION! Before using the appliance read these instructions carefully. It contains important information on your safety as well as recommendations on proper appliance use and maintenance.

Thank you once again and Happy Cooking!









The Yum Asia Team

1. IMPORTANT SAFEGUARDS Please follow these instructions

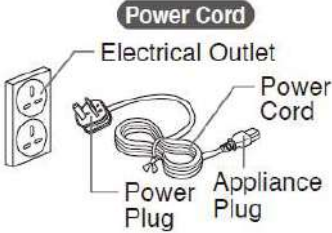

THESE WARNINGS AND CAUTIONS ARE INTENDED TO PREVENT PROPERTY DAMAGE OR PERSONAL INJURY TO YOU AND OTHERS.

	<p>Do not modify this rice cooker, only a repair technician may disassemble or repair this unit.</p>		<p>Do not allow children to use the rice cooker unsupervised. Keep it out of reach of very young children. Children are at risk of burns, electric shocks or injury.</p>
	<p>Do not touch the steam vent. Doing so may cause scalding, burns. Take special care with children</p>		<p>Do not open the lid or move the rice cooker during the cooking cycle. Doing so may cause burns – the steam is very hot.</p>
	<p>Do not plug or unplug the power cord with wet hands. Doing so may cause electric shocks or injury</p>		<p>This rice cooker is for cooking rice and other dishes detailed in this manual. Do not use other than for the intended purposes. Always follow the operating instructions and never cook the following: Foods packed in plastic Dishes that use paper towels or other lids to cover the food. Doing so may cause the steam vent to clog.</p>
	<p>Do not immerse the rice cooker in water or splash with water. Doing so may cause a short circuit or electric shocks.</p>		
	<p>Do not put any metal objects in the air vents. Doing so may cause electric shocks or malfunction resulting in injuries.</p>		<p>A loosely inserted power plug may cause fire, electric shocks, short circuit, smoke or fire. Use only an electrical outlet that is rated at 15 amperes minimum.</p>
	<p>Insert the power plug completely and securely into the electrical socket.</p>		<p>If the blades of the plug are dirty, wipe them clean. Debris on the blades of the plug can cause fire.</p>

	<p>This appliance is intended for household use only. Any use for commercial purposes will void the warranty.</p>		
	<p>Do not use if the power cord or plug is damaged or if the power plug is loosely inserted into the electrical socket. Doing so may cause electric shocks, short circuit or fire. Do not damage the power cord.</p>  <p>Do not bend, twist, bundle or attempt to modify the power cord. Do not place the cord on or near high temperature surfaces or appliances, under heavy items or between objects. A damaged power cord can cause electric shocks or fire.</p>		<p>Unplug the power cord from the electrical socket when not in use</p>
	<p>Do not use any other parts other than those supplied with this rice cooker.</p>		<p>Allow enough space next to walls, other furniture and under shelves for the steam to escape.</p>
	<p>Do not use this rice cooker in a place where it may come in contact with water or other heat sources.</p>		<p>Do not touch hot surfaces during, or immediately after, use. Be careful of steam when opening the lid and be careful not to touch the inner bowl while stirring the rice. Touching hot surfaces with metal parts like the inner lid, inner bowl and heating plate may cause burns.</p>
			<p>Do not place or use this rice cooker on an uneven surface or on a surface that is vulnerable to heat. Doing so may cause fire.</p> <p>Do not use this rice cooker on a slide-out table or shelf with insufficient load capacity. Doing so may damage the table or shelf, causing the rice cooker to fall, resulting in injury or burns. Any shelf or slide-out table must have a load-bearing capacity of at least 18kg.</p>



IMPORTANT!

Allow the rice cooker to cool down before cleaning. Hot parts like the inner lid, inner bowl and heating plate may cause burns.

Always unplug the rice cooker by holding the power plug, not by pulling the power cord.

Insert the end of the power cord firmly into the rice cooker, otherwise it may cause electric shocks, fire and the rice cooker may not work.

Do not cover the main body of the rice cooker, especially the steam vent while cooking.

Do not damage the inner bowl or inner lid. A deformed inner bowl or lid will cause uneven cooking results.

Make sure nothing is stuck to the heating element or the outside of the bowl. This will cause uneven cooking results.

Do not splash water on the rice cooker. This may cause the breakdown of the unit, fire or electric shock.

Do not use the rice cooker in direct sunlight. This may cause discolouration.

Do not use where the steam from this rice cooker may come into contact with other appliances. The steam may cause discolouration, malfunction, fire to other appliances.

Do not use on a surface where the air vents underneath could get blocked (like on paper, carpet, plastic)

Do not cook when the inner bowl is empty. This may cause the breakdown of the unit.

Stop using immediately if you notice ANY of the following:

The power plug or cord has become very hot.

The power cord is damaged or the electricity turns on/off when touched

The body of the rice cooker is deformed or unusually hot

Smoke is coming from the rice cooker or there is a burning smell

Any part of the rice cooker is cracked, loose or unstable.

2. APPLIANCE DESCRIPTION

Your Kumo fuzzy logic rice cooker is a modern multi-function cooking appliance using the highest quality manufacturing and our years of experience selling rice cookers.

Saving space in your kitchen, this appliance combines quality functions of speciality rice cooking with porridge, steam and slow cook. Kumo has a unique YumCarb option for preparing lower carb rice. We designed this rice cooker with additional features that any cook will find useful. An easy to use Smart button control function panel with adjustable timings for different functions will make cooking so much easier and produce delicious rice or full meals

2.1 APPLIANCE DESIGN

Meet your Kumo rice cooker! It is supplied with a rice spatula, a soup ladle, a measuring cup and a YUMCARB stainless steel steam basket (which can be used for lower carb rice or steaming other foods).

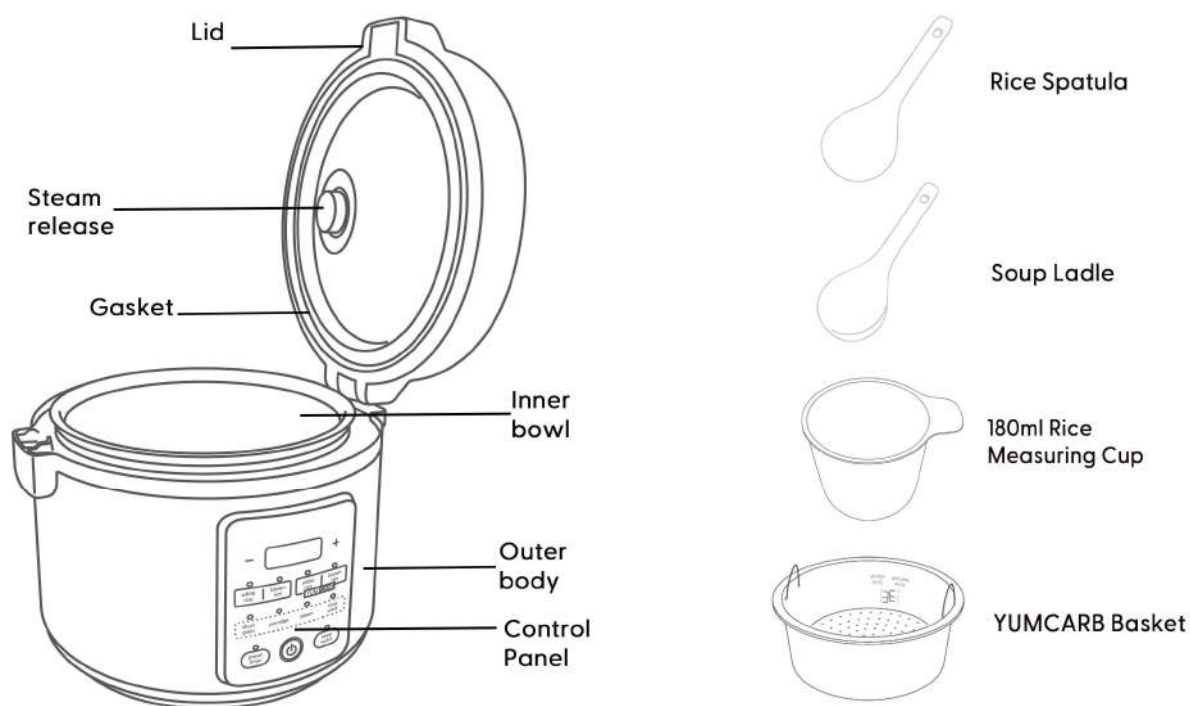

2.2 CONTROL PANEL DISPLAY

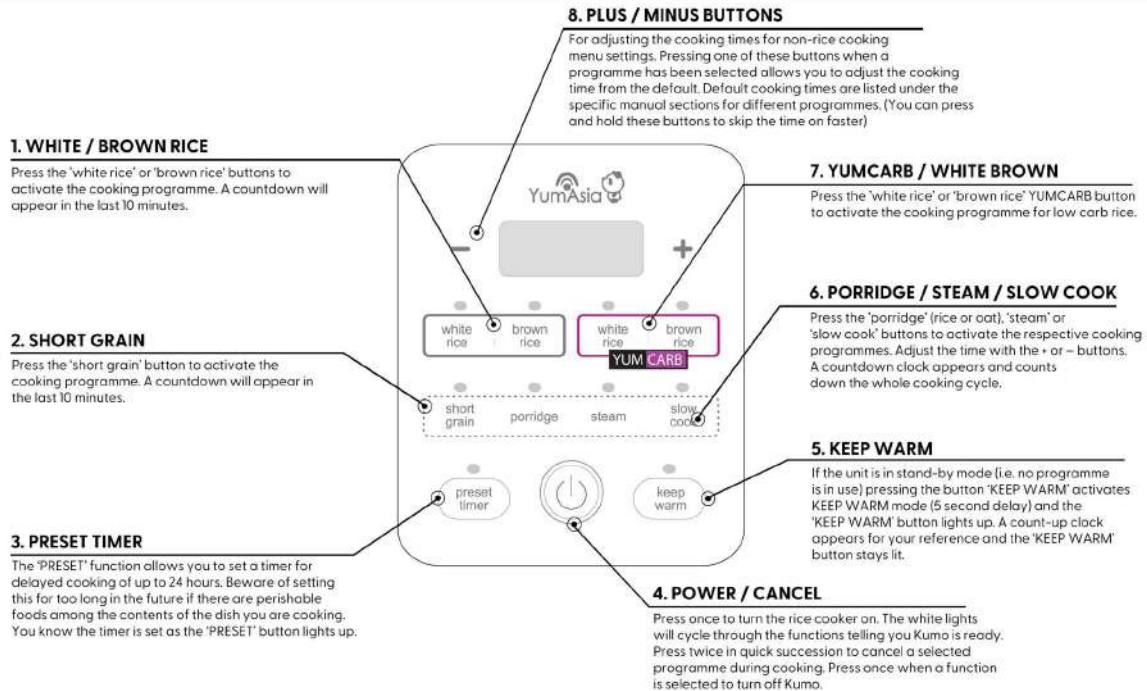

3. APPLIANCE OPERATION

3.1 BEFORE USE

1. Open the packaging, take out the appliance carefully, and remove all packaging and promotional material.
2. Take out all the accessories and the operating manual.
3. Remove any promotional stickers. Wipe the appliance case with a wet cloth.
4. Wash the bowl and inner lid in warm soapy water with a soft sponge. Dry it thoroughly.
5. Cook ½ cup of rice (for water, fill measuring cup to ½ with water) and throw it away.

3.2 NAVIGATING THE CONTROLS

The display of this unit uses Smart button controls and is easy to use with a bright 'Ice White' display. Press the button you want to use firmly, you will see that each button is slightly raised, so it's easy to press. Buttons have a light above that indicates the programme has been selected.

3.3 HOW TO USE THE RICE COOKER FUNCTIONS

NOTE - the maximum capacity of this appliance (Do Not Exceed!)
5.5 cups (180ml cup) for WHITE rice
4 cups (180ml cup) BROWN rice
3 cups (180ml cup) for WHITE or BROWN YumCarb rice

Kumo is designed to cook rice using 7 distinct phases to produce perfect rice every time and to carefully retain nutrients. These phases are Preheat, Absorb water, Heating, Boiling, Braising, Absorb water and then finally Keep warm (in this order). This phased cooking and adjustments in temperature are controlled using Kumo's fuzzy logic processor.

OPTIONS FOR COOKING RICE:

1. **'WHITE'** setting is for cooking long grain white rice (for example, basmati, jasmine or Thai fragrant rice)
2. **'SHORT GRAIN'** setting is for any type of white short grain rice like pearl or sushi rice and Thai sticky rice.
3. **'BROWN'** setting is for cooking long or short grain brown rice
4. **'YUMCARB WHITE'** setting is for preparing any type of white rice with a lower carb value.
5. **'YUMCARB BROWN'** setting is for preparing any type of brown rice with a lower carb value.

Approximate cooking times for different types of rice

Rice Selected	'LONG GRAIN'	'SHORT GRAIN'	'BROWN'	'YUMCARB WHITE'	'YUMCARB BROWN'
Time taken	35 mins	37 mins	60 mins	40 mins	60 mins

There are markings on the inside of the inner bowl to indicate the water levels for white long grain rice, white short grain rice, brown rice and (rice) porridge. There are also markings on the YumCarb steaming basket for white rice and brown rice.



During the rice cooking cycles, a chasing lines pattern comes on the display to indicate Kumo is cooking, a **countdown** will appear in the **last 10 minutes**.

Cooking **STICKY** or **GLUTINOUS** rice

Sticky or glutinous rice is different to normal short grain rice. If you are cooking sticky/glutinous rice you need to follow the water guidance below and use the short grain setting.

Water levels for 'THAI STICKY/GLUTINOUS' rice

Cups of rice	1	2	3	4	5
Water level on bowl (short grain marks)	1.5	2.5	3.5	4.5	5.5

3.3.1 COOKING RICE IN KUMO

1. **Measure** the rice with the measuring cup provided. Make sure the rice is level to the top of the cup – this is a full cup (180ml) measurement.
2. **Clean** the rice (if needed) as directed in '4.1 HOW TO COOK PERFECT RICE'. Place the inner bowl into the appliance, **put the rice into the inner bowl** and **fill to the water line** that corresponds to the amount/type of rice you are cooking.
3. Close the lid and **select** the rice setting you want to cook with. There is **no start button**, the cooking cycles will **start automatically after a 5 second delay**.



Also see the 'Speedy Start Guide' on the back of the warranty card for a step-by-step guide on how to cook rice and 'Tips to Cooking Great Tasting Rice' on page 11 for more detailed cooking information and advice and page 15 for more details on YumCarb rice.



If you want to cook **½ cup of rice**, there isn't a mark on the inner bowl for this. Use the measuring cup to add the water – 1/2 a measuring cup of water for white rice and ¾ cup of water for brown rice.

3.4 HOW TO USE THE KEEP WARM FUNCTION

Once a cooking cycle has finished, the appliance will automatically switch to 'KEEP WARM'. You can activate 'KEEP WARM' when the appliance is on stand-by (i.e. when no menu functions have been selected) by pressing the 'KEEP WARM' button. There will be a 5 second delay and the keep warm will start, the button will then light up and a count-up clock will appear on the display for your reference. The 'KEEP WARM' function can be used for 24 hours but you might find the rice ruins after 15 hours use.

To cancel 'KEEP WARM', press the power button (it doubles as the 'CANCEL' button), this cancels the programme and turns the unit off.

3.5 HOW TO USE THE OTHER COOKING FUNCTIONS

3.5.1 PORRIDGE

This menu setting can be used for Asian rice porridge or oatmeal porridge. For recipes, see page 13. The default cooking time for the 'PORRIDGE' setting is 1.5 hours. You can adjust this down to 1 hour or up to 3 hours using the + and - buttons in 5 minute intervals once you have selected the 'PORRIDGE' setting and the light is flashing.

After selecting the time, there is a 5 second delay and the cooking cycle starts. Once the cooking cycle is complete, the appliance will make a sound and will automatically switch to 'KEEP WARM'.

3.5.2 STEAM

Using the provided stainless steel steaming basket, you can steam different types of food. You can cook rice and steam food at the same time (1 cup of rice maximum) but cannot steam and cook rice with the YUMCARB functions.

The default cooking time for the 'STEAM' setting is 10 minutes. You can adjust this down to 5 minutes or up to 1.5 hours in 5 minute intervals using the + or - buttons once you have selected the 'STEAM' setting and the light is flashing. After selecting the time, there is a 5 second delay and the cooking cycle starts. There will be a countdown on the display – this will only start to countdown when the water has been heated. Using hot water rather than cold water helps speed up the heating process.

See Section 5, page 12 for a guide to steaming

3.5.3 SLOW COOK

For cooking stews and other dishes like curries, dhal, or other pulses/grains select the 'SLOW COOK' setting.

The default cooking time for the 'SLOW COOK' setting is 2 hours. You can adjust this up to 6 hours using the + or - buttons in 5 minute intervals once you have selected the 'SLOW COOK' setting and the light above is flashing (you can press and hold to skip the time on faster). After selecting the time, there is a 5 second delay and the cooking cycle starts. The appliance heats the contents of the inner bowl to a high temperature (you will hear bubbling from the liquid), it then switches to a lower temperature for the slow cooking. This is the same as the 'auto' setting on a conventional slow cooker. Once the cooking cycle is complete, the appliance will make a sound and will automatically switch to 'KEEP WARM'.



Kumo is a very efficient, sealed unit fuzzy logic rice cooker, the slow cook setting will cook food faster as there is no heat loss. A normal slow cooker recipe with a cook time of 7-8 hours will take 3-4 hours to cook in Kumo. This is to give a more efficient slow cook.

3.6 CANCELLING PROGRAMMES

To cancel a programme, you have selected or if you want to stop a programme part way through the cooking cycle, you just need to press the 'power' button once. The appliance will then switch off.

To switch the appliance to stand-by when a cooking programme has been selected, press the 'power' button twice in quick succession.

3.7 HOW TO USE THE DELAYED START (PRESET) FUNCTION

The 'PRESET' function is a useful timer/delayed start feature; this allows you to set the appliance to have your rice or food ready at a specific time. The 'PRESET' function is available for all settings.

To set the timer:

1. Press the button for the cooking programme you want (for non-rice cooking programmes you can programme the length of cooking time at this point).
2. Then press the 'PRESET' button which will then light up.
3. By pressing the '+' and '-' touch buttons you can select the hours in advance in 5 minute increments) when the rice/dish should be ready.
4. After setting when you want the food to be ready, there is a 5 second delay, and the cooker will display the hours in advance you selected, start to count down and the cooking cycle will complete at the time you specified.

If the preset/timer is set to below the minimum stated in the below table, the cooking cycle will start immediately. This is because the default cooking time for each cooking cycle has to be taken into account along with additional assessment time for the fuzzy logic to know what it is cooking.

Suggested timings for the 'PRESET' function

Function	RICE	PORRIDGE	STEAM	SLOW COOK
Preset timings	70 mins to 24 hrs	70 mins to 24 hrs	1 hr to 24 hrs	130 mins to 24 hrs



The start time of the preset/timer is not exact, it will come on slightly earlier as Kumo has to assess what exactly is in the inner bowl (rice/oats/water) and volume so it can calculate the cooking time effectively. It deals with this by turning the unit on early so it can 'assess' the contents.

4. COOKING GREAT TASTING RICE

4.1 HOW TO COOK PERFECT RICE

Measure the rice accurately! Use the measuring cup provided as other cup sizes may be different measurements. Make sure you level the rice off at the top of the cup – this is a full 180ml measurement.

Rinse the rice! Place the rice into a sieve or a bowl and pour fresh, cold water on top. Stir the rice loosely by hand and drain the water. Do this 2-3 times until the water you are rinsing with runs clear.

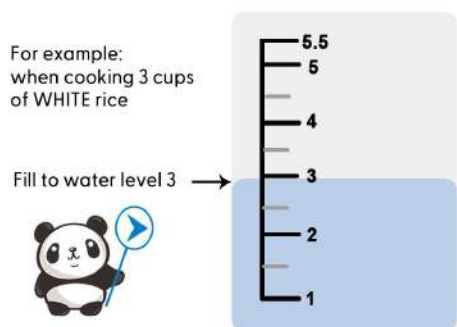

Be accurate with the water!

The amount of water in the inner bowl prior to cooking greatly affects the texture of the cooked rice. The more water you use, the softer the rice will be when cooked. We recommend after washing the rice, you place in the inner bowl, then top up with water to the corresponding line on the inner bowl – fill to the underside of the line, this will give you perfect rice. If you prefer it softer, fill to the top of the line; if you prefer it harder, fill to 2-3mm below the line.

Stir and loosen! Once the appliance has switched to 'KEEP WARM', if possible, stir and loosen the rice straight away with the provided spatula. This helps release excessive moisture and results in nice, perfect fluffy rice.

4.2 OUR TIPS FOR RICE COOKING AND GETTING PERFECT RESULTS



Try and choose bags of rice with as few broken grains as possible, as broken grains make rice very soggy and sticky.



It is important to remember that every batch of rice is different - even the rice you regularly buy can sometimes change for the worse quality - each batch of rice absorbs water differently depending on how well it's been processed. The end result can also depend on the age of the rice you use. Newer rice needs less water than older rice but, of course, there is no way of knowing whether the rice you have bought is an older or newer picked grain.



If the rice you cook is too sticky, it's worthwhile trying a batch without rinsing, as some varieties of rice don't need rinsing as they have been processed differently. Unlike pasta, rice isn't consistent because it's a natural product and the first batch cooked from a new purchase of rice can be hit and miss – the rice cooker does mitigate this to an extent, but adjusting the amount of water is a sure way of getting the rice you like.



If the rice you cook is too soft, next time reduce the water you add for cooking by 3-4mm, softer rice means that there was too much water in the inner bowl during cooking. If the rice you cook is too hard, next time add 3-4mm more water, harder rice means that there was too little water in the inner bowl during cooking.



Do not use any kind of quick cook, partially cooked, parboiled rice – look at rice packets carefully to make sure the rice you are buying is suitable. This type of rice is not suited for use in a sealed unit, fuzzy logic rice cooker.

5. HOW TO USE THE STEAM FUNCTION

You can use this appliance as a stand alone steamer (use 1.5-2 cups of water) or you can cook rice at the same time as steaming food. If steaming whilst cooking rice, you would use the rice function for the type of rice you are cooking and add the steaming basket to the inner bowl above the rice.

Here is a guide for estimated cooking different types of food on the 'STEAM' function:

INGREDIENTS	AMOUNT	COOKING TIME	TIPS FOR STEAMING
Carrot	150g	20 mins	Cut into bite-size pieces
Broccoli	150g	15 mins	Cut into bite-size pieces
Spinach	80g	15 mins	Cut into bite-size pieces
Pumpkin	200g	20 mins	Cut into bite-size pieces
Potato	250g	40 mins	Cut into bite-size pieces
Sweet Potato	200g	35 mins	Cut into bite-size pieces
Corn	150g	30 mins	Cut into bite-size pieces
Chicken	250g	30 mins	Make cuts on side touching steam basket
Fish (white fish and salmon)	150g/cut into fillets	25 mins	Slice to less than 2cm and wrap in foil
Prawn	150g/7 pcs	20 mins	Steam without removing shells
Scallop	150g	20 mins	Remove from shell (recommended to line the steam basket with Chinese leaves or similar to prevent sticking)
Refrigerated Meat Dumpling	150g	15 mins	Leave space between foods
Frozen Meat Dumpling	150g	20 mins	Leave space between foods



IMPORTANT - Do not steam food over 3.5cm thick.

If you would like to combine cooking rice with steaming, it is recommended that **1 cup of rice is the maximum capacity you can cook**. Any more than this, there is a danger as the rice cooks, the steaming basket will push into the lid and pop it open.



If cooking rice and steaming at the same time, you can open the lid (very carefully, minding the steam that is released from the unit) to add the steaming basket part way through the cooking cycle so the vegetables are not over-cooked.

6. RECIPES

Here are a couple of recipes to start you off with your new rice cooker. For lots more recipes like flavoured rice (Mexican and coconut rice), risotto, stews, soups and more, please see our foodie blog at www.greedy panda.co.uk.

RICE PORRIDGE (CONGEE)

Ingredients (2-3 servings)

½ cup of rice
35g chicken thighs, chopped and parboiled
Pinch of salt
Ginger and spring onion (scallion), shredded – to taste

Directions

1. Wash rice and place into inner bowl, add water (to ½ mark on the porridge scale) then place the chicken on top
2. Press the 'PORRIDGE' button and the cooking cycle will start after a 5 second delay
3. When the rice cooker turns to 'KEEP WARM' add salt if you want it and garnish with ginger and spring onions

OATMEAL PORRIDGE

Ingredients (serves 2 – do not exceed quantities)

½ cup steel cut or high quality rolled oats (we advise you put these in a sieve and shake hard 3-4 times to dislodge any sediment)
1.5 cups water (measured in the provided measuring cup)
½ cup of milk (or cream) or 1/2 cup of coconut milk – whatever you prefer
2-3 spoons (or more to your own taste) honey or brown sugar
* You may need to experiment with the amounts of oats and water, depending on whether you like thick or thin oat porridge! You can also use chopped up apple or cocoa powder to flavour the porridge.

Directions

1. Place the inner cooking pan in the main body of the rice cooker, place oats and water in the inner cooking pan and plug in the unit. Select the 'PORRIDGE' setting and adjust the timing to what you prefer (longer cooking time = thicker porridge; less cooking time = thinner porridge). The cooking cycle will start after a 5 second delay
2. When the rice cooker turns to 'KEEP WARM', open the lid, stir and add the remaining ingredients. Using the Timer function and soaking the oats overnight will help soften the texture.
3. Add any dried or fresh fruit to the porridge instead of sugar – delicious and healthy on a cold winter's day!!



Do not use milk to cook the oats, this is result in a 'boil over' of the contents as milk reacts differently when heated. **Only use water to cook the oats.**

SUSHI ROLLS

Ingredients (4-5 servings)

3 cups of rice
For the sushi seasoning (vinegar mix) – 4 tbsp rice vinegar, 1 tbsp sugar, 1.5 tsp salt
Whatever topping you prefer (sashimi, prawns, pickles, natto, salmon roe, eel)
Seaweed, wasabi, soy sauce and pickled red ginger for garnish

Directions

1. Wash rice and place into inner bowl, add water (follow the water levels on the inner bowl and use the 'SHORT GRAIN' menu option)
2. When the rice cooker turns to 'KEEP WARM' place the rice in a wooden container (wiped with a clean, wet cloth) and pour the vinegar mix over the rice, mixing whilst cooling with a fan
3. Hand rolled sushi is simple and quick, it's just a case of wrapping your favourite ingredient with nori (seaweed)

RICE PUDDING

Ingredients (cup measures are for the rice measuring cup)

1 cup arborio, other short-grain rice or sticky/glutinous rice

¼ cup evaporated milk, ¼ cup coconut milk, ½ cup sweetened condensed milk**

1 cinnamon stick or pinch of ground cinnamon, 1 lemon zest, one large piece of lemon peel

¼ teaspoon nutmeg (or less if you prefer)

A sprinkle of ground cinnamon (to garnish)

Directions

1. Measure your short grain rice with the measuring cup you got with your rice cooker.
2. Measure the rice, then rinse rice in cold water, place rice and water (to the correct line on the inner bowl) into the rice cooker, choose the 'SHORT GRAIN' rice setting.
3. Meanwhile whisk evaporated milk, coconut milk, sweetened condensed milk, cinnamon stick (or ground cinnamon), lemon zest (a large thin slice of zest, not grated) and nutmeg together.
4. When rice is cooked and the rice cooker has switched to keep warm, add the whisked milks into the rice, close the lid. Check about 30 minutes later and see if it is at the consistency you like.
5. Discard the cinnamon stick (if using) and the lemon zest.
6. Place into individual dishes and garnish with ground cinnamon and cream if desired.



** Vegan adaptation - this can also be made without the evaporated milk and condensed milk as a non-dairy alternative.

Use one whole tin of coconut milk and some non-dairy milk to loosen it after stage 5 if necessary.

7. COOKING WITH OTHER GRAINS/PULSES IN KUMO

It's possible to cook other grains and pulses in Kumo, you would need to experiment with adjusting water levels and selecting the correct cooking cycle. Here is a rough guide that may help cooking other grains and pulses in Kumo.

QUINOA

If it's not pre-washed, make sure you rinse it well in a sieve with cold water. Use a 1:1 ratio of quinoa to water (up the water to 1:1.25 if you are using black quinoa) and use the white rice setting. Once it's finished cooking, fluff up a little and leave on keep warm for 5-10 minutes.

COUS COUS and GIANT COUS COUS

Use the water amounts indicated on the packet and use the white rice setting.

MILLET

For each portion you want to cook, measure 1/4 cup of millet into the inner bowl and add 1 cup water for each portion (so if you use 1 cup of millet, add 4 cups water; using the measuring cup to measure the water)

Shake a small dash of salt into the water, then close the lid. Plug in the rice cooker and select the 'Porridge' cycle. You can either cook straight away adjusting the timing for how you prefer your millet (longer cooking will have a thicker consistency; less cooking will have a thinner consistency) or you can use the preset timer for when you will want to eat in the morning. Once cooked you can add whatever flavouring you prefer

LENTILS and BEANS

The slow cook setting is ideal for cooking lentils or beans – rinse beforehand and follow the water levels indicated on the pack. The porridge setting also works for cooking lentils and beans, if you want to cook at a lower temperature.

PEARL BARLEY

The slow cook setting is ideal for cooking pearl barley - rinse before cooking and follow the water levels indicated on the pack. Using pearl barley in a batch of soup will cook within an hour but won't overcook if left for longer.

8. YUMCARB EXPLAINED

YUMCARB rice cooking function is unique to Kumo. This is rice with a lower carb value than conventionally cooked rice.

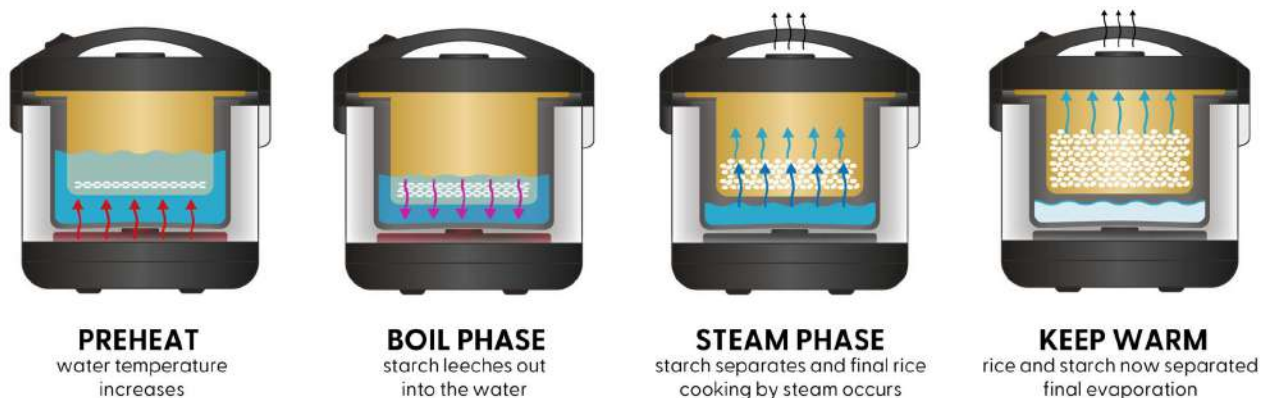

By placing the rice into the stainless steel YUMCARB basket, the rice is submerged in water at the beginning of the cooking cycle. When first activated, the display shows 0:25 (or 0:40 for brown rice) and will stay this way during the first 25/40 minutes of the cooking cycle. During this time, Kumo is gradually raising the temperature inside the unit to the optimal temperature for boiling away the excess water. This process gives time for the starch to leech out of the rice and break down (starches are easily-dissolvable). The starchy water drains down through the holes in the YUMCARB basket, which doesn't allow for the starches that have leached into the water to be reabsorbed into the rice.

The rice finishes cooking during the last 25 minutes of the cooking cycle - Kumo will start counting down. This last phase of the cooking cycle is crucial as it steams the rice in a lowered carbohydrate state, thereby reducing their levels in the rice by up to 25%*.

* Based on lab testing, a reduction of 25% less carbohydrates was shown in white rice. Certified by Testing Institute of Product Quality Supervision, China

8.1 HOW TO USE THE YUMCARB FUNCTION

1. Place the YUMCARB basket into the inner bowl. Add rice (rinse first if your rice needs it) and then add water to the corresponding line (there are 1-3 marks for white and brown rice). Don't worry about the amount of water you are adding – it seems a lot but this is boiled away rapidly. If you find the rice is too soft, reduce the water next time.
2. Close the lid, select **YUM CARB** you have a choice of white or brown rice. After a 5 second delay, the cooking cycle will start and 0:25 (for white rice) or 0:40 (for brown rice) will be on the display.
3. After the time displayed has elapsed, the display will countdown to 0:00, the appliance will make a sound and will automatically switch to 'KEEP WARM'.
4. Stir the rice well. The rice at the bottom of the YUMCARB basket will seem very wet, this is normal – mix the rice up really well, lifting the rice from the bottom to the top and leave on keep warm for at least another 10 minutes.
5. There will be starchy water left in the inner bowl underneath the YUMCARB basket. When removing the YUMCARB basket to serve the rice, be careful as the stainless steel will be very hot. The starchy water can be discarded.

When using the YUMCARB rice cooking functions, you may find that the condensation collector becomes full – this is due to the amount of water that is evaporated from inside. If the condensation collector is completely full, you may find that when you open the lid, some water may spill out from the lid – be careful as this water is hot.

9. CLEANING AND MAINTENANCE

Always remove any remaining pieces of food and clean immediately after use.

Do not use any kind of metal brush, scrubber or harsh chemicals/solvents to clean the dirty parts of the appliance. If anything remains stuck to the inner bowl, pre-soak with a little washing up liquid before washing. Do not immerse the appliance in water. Use a damp sponge or soft cloth to clean the outer case. Do not wash rice in the inner bowl, this can cause scratches and the inner bowl coating to deteriorate.

IMPORTANT - Never put the inner bowl into a dishwasher. The chemicals and washing cycle of a dishwasher are too harsh.

Any damage caused by a dishwasher will not be covered by our warranty.

STEAM CAP CARE

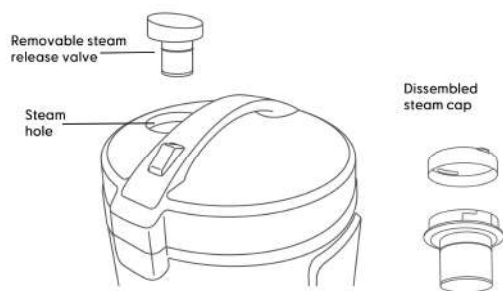

The steam cap on top of the lid is removable – pull upwards to remove.

Wash this on a regular basis.

The removable steam cap can also be full disassembled to ensure full cleaning – ensure this is put together properly before use.

IMPORTANT INNER BOWL CARE

Only ever use the plastic accessories provided, you can also use wooden or silicone accessories. Never use metal to stir as this will damage the ceramic coating on the inner bowl.

Cleaning the inner bowl is easy, but if anything remains stuck to the inner bowl, pre-soak with a little washing up liquid before washing.

Do not pour vinegar into the inner bowl as this will damage the ceramic coating.

The outside (underneath) of the inner bowl will discolour and scuff due to the heat being applied to the bowl from the heating element, this is normal. The ceramic coating on the inner bowl may change colour over time. This is completely normal and nothing to worry about.



CONDENSATION COLLECTOR CARE

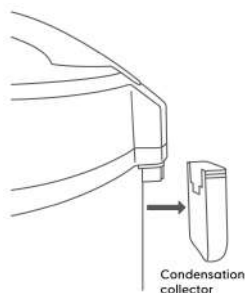

The condensation collector on the side of the appliance can be removed. There are grooves where the condensation collector slot into. Make sure the condensation collector is properly in place

Remove and empty the condensation collector. Wash, dry and install it back into place.

10. REPLACEMENT PARTS

If you need spare parts, please contact us via our website www.yum-asia.com or e-mail hello@yum-asia.com.

Spare parts available for Kumo YUM-EY10 (measuring cups are available to purchase on our website):

Part Name	Part Number
Ceramic coated inner bowl	IB- EY10
YUMCARB basket	SB- EY10

11. TROUBLESHOOTING GUIDE

PROBLEM		POSSIBLE CAUSE
COOKING RICE	Rice cooks too hard or too soft	<ul style="list-style-type: none"> Make sure the appliance is on a flat surface, if it is on an uneven surface, the water level becomes inconsistent and it will affect the cooking of the rice. The texture of rice varies depending on how it's been processed (see section 4.3 for more information) Using the 'PRESET' function can result in a softer rice texture if the rice has soaked in the water for a length of time. Make sure the inner bowl isn't deformed Did you loosen the rice after cooking? If not, do this to allow excess water to evaporate
	Rice is scorched/burnt	<ul style="list-style-type: none"> Make sure nothing is stuck to the heating element or bottom of the inner bowl Rice may not have been washed enough, leaving too much starch on the rice

PROBLEM		POSSIBLE CAUSE
		<ul style="list-style-type: none"> • Make sure the inner bowl isn't deformed
	Boils over while cooking	<ul style="list-style-type: none"> • Check the setting you have selected and the water level you have filled to • Make sure the steam vent cap is on the appliance
	A noise is heard during cooking or keep warm	<ul style="list-style-type: none"> • A clicking noise is just the microprocessor (MICOM) adjusting the cooking temperature of the appliance, it is nothing to worry about • A 'sparking' noise may occur if the inner bowl has any kind of moisture on the bottom of it as the heating element warms. Make sure the inner bowl is completely dry.
	Steam comes out from between the outer lid and main body	<ul style="list-style-type: none"> • Check the outer lid is fitting properly and has not deformed. • Is the outer lid gasket dirty? If so, clean the outer lid gasket
STEAMING	Food does not steam	<ul style="list-style-type: none"> • Is there sufficient water for steaming? Make sure there is water to at least the two cup mark on the inner bowl • Is there too much food in the steaming basket? – reduce the amount of food or increase the cooking time • The food may be in too large pieces, reduce the size of food pieces or increase the cooking time
	Steamed food is too hard	<ul style="list-style-type: none"> • Vegetables – steaming time was too short. Make sure there is enough water and continue to steam • Fish and meat – steaming time was too long. Reduce the cooking time
	Steamed food is cold	<ul style="list-style-type: none"> • Has too much time elapsed from when the cooking cycle ended? Try not to leave on 'KEEP WARM', remove immediately from the appliance and eat
KEEP WARM	Rice has a smell, is yellow or there is excessive moisture	<ul style="list-style-type: none"> • Do not keep very small amounts of rice on 'KEEP WARM' • Has the 'KEEP WARM' been used for more than 15 hours? • The type of rice and water may have caused the rice to look yellow • Was the spatula left in the inner bowl whilst on 'KEEP WARM' • Did you loosen rice immediately after it had cooked – if not, loosen • It may be a left over smell from a previous cooking cycle (especially if slow cooking dishes)
TIMER COOKING	Appliance starts cooking immediately	<ul style="list-style-type: none"> • The minimum default time is 70 minutes, anything less than this will start the cooking cycle immediately
	Food isn't ready at the set time	<ul style="list-style-type: none"> • Cooking may not complete at the set time if the temperature in the room or the water level is too low • Was there a power cut? This will cause the unit to reset

12. SPECIFICATIONS AND COOKING TIMES

Model name and number	Kumo, YUM-EY10D-SEA/YUM-EY10L-SEA
Capacity	1 litre (1 to 5.5 cups) rice cooker
Rating	AC 220-240V, 50/60Hz
Electric consumption	500W
Average power consumption on 'KEEP WARM'	21W
Cooking system	Direct heating
Country of manufacture	China
Length of power cord	0.9m
External dimensions (approximate)	27cm (length) x 27cm (width) x 26cm (height)
Weight (approximate)	2.36kg

	FEATURE	CAPACITY	APPROX. COOKING TIMES
COOKING CAPACITY (cups or litres)	White Long grain	1-5.5 cups/1l	35-40 minutes
	White Short grain	1-5.5 cups/1l	37-40 minutes
	Brown	1-4 cups/0.72l	60-66 minutes
	YUMCARB white	1-3 cups/0.54l	35-40 minutes
	YUMCARB brown	1-3 cups/0.54l	60-66 minutes
	Porridge (rice)	¾ cups/0.13l	1 hour, can be adjusted to 3 hours maximum
	Porridge (oat)	½ cup/0.09l	1 hour, can be adjusted to 3 hours maximum
	Steam	Water to 1 or 2 cup rice mark	5 minutes, can be adjusted up to 1.5 hours maximum in 5 mins intervals
	Slow Cook	2 litre	2 hours, can be adjusted to 6 hours maximum

13. CERTIFICATION AND WARRANTY

Included with this appliance is our comprehensive warranty (please see warranty card included). For more details of our warranty go to www.yum-asia.com/sea/warranty

This Yum Asia rice cooker and multi-function cooker is designed for DOMESTIC USE ONLY. Its use in a commercial setting will invalidate this warranty.

If you encounter a problem with your appliance, please first look at the 'Troubleshooting' guide on page 17 of the manual to see if your problem is listed there.

If you continue to have a problem, please e-mail hello@yum-asia.com with your order details, a description and photos of the problem.

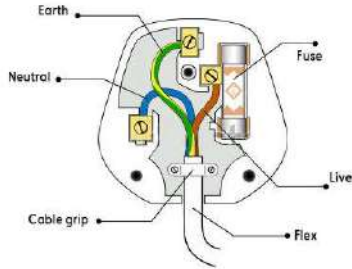

IMPORTANT! - The wires in this mains power cord are coloured as:

Green and yellow = Earth Brown or Red = Live Blue or Black = Neutral

Connect the Earth wire (green and yellow) to the terminal in the plug which is marked with the letter E or by the earth symbol or coloured green and yellow. Connect the Neutral wire to the terminal which is marked with the letter N or coloured black. Connect the Live wire to the terminal which is marked with the letter L or coloured red. This appliance must be protected by a 13A fuse if a 13A (BS1363) plug is used.

YUM ASIA

UK – USA – EU - SEA

www.yum-asia.com

© Yum Asia

UK OFFICE

Yum Asia
Scan Global Limited
Unit 14, 5 Mills Road
Aylesford
Kent ME20 7NA

HONG KONG OFFICE

Yum Asia
Sea-Air Logistics (HK) Ltd,
G/F., "J" Warehouse,
No. 1-7 Sai Tso Wan Road,
Tsing Yi Island, Hong Kong



Ninja
Ceramic Bowl